



# City of Emmonak

P.O. Box 9, Emmonak, Alaska 99581  
(907) 949-1227 • (907) 949-1249 • Fax (907) 949-1926  
email: emkcity@gmail.com

Honorable Governor  
Michael Dunleavy  
Office of the Governor  
P.O. Box 110001  
Juneau, Ak 99811-001

Honorable Director  
Mike Sutton  
Division of Homeland Security  
Emergency Management  
Building 49000  
Army Guard Road  
JBer, Ak 99505

Date: March 25, 2020

Ref: Declaration Emergency COVID -19

Dear Honorable Governor Dunleavy & Honorable Director Sutton,

Since 1999 I had the honor to carry out many responsibilities for Community of Emmonak. On many important aspects of these challenges, working with State of Alaska and Federal Government I have no words, such that would express so noble Public Assistance provided in the posted by Federal Government, and by State of Alaska, the perpetual Water and Sewer upgrades and other projects both of State and Federal Government are gratifying more then what humble words can express.

We know the truth, we've all experienced in our historical events, and know of one community had 80 people during one day, and two survived the next day.  
COVID – 19 pandemics is not far from this reality.

In this packet of documents please find and review, we appreciate all that State of Alaska and Federal Government has done to date.

1. The Declaration of Public Health Emergency enacted by Resolution No. 20 – 04
2. A Resolution of the Emmonak City Council seeking funding's from the State of Alaska and Federal Government for Water and Sewer system repairs and services and heating fuel enacted by Resolution No. 20 – 05

3. The City of Emmonak share the contends of delicate concerns related to Coronavirus COVID – 19 Travel Advisory Declaration Resolution No. 20 – 06 was enacted on March 23<sup>rd</sup>, 2020

Document 1

The Declaration of Emergency is 2 pages sign by Wilbur R. Hootch Mayor and is self-explanatory.

The second Resolution No. 20 – 05 is seeking and request for funding the resolution is 3 pages with Document 1 Six (6) pages explaining current shortage of heating fuel.

Document 2

Emphasizing Water and Sewer service lines are important to provide potable water to family with Eleven (11) pages.

Document 3

Is the same as above accept it already has Water/Sewer services lines connected, plumbing repair is required with other items damaged to be replaced Six (6) pages for back up.

Document 4

Is provision of non-payment due in hardship of the individual City Council advise they be connected to Water and Sewer system Plant Operators and the Accounting Department have been notified required of the action Four (4) pages.

Most Respectfully on behalf Mayor and Council Members

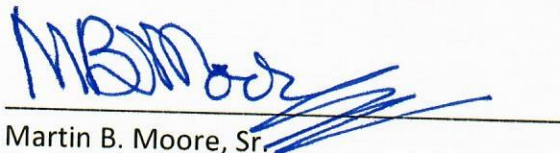

Martin B. Moore, Sr.  
City Manager  
City of Emmonak

Cc; State Senator Donny Olson  
State Rep. Neal Foster  
Alaska Village Electric Co-operative (AVEC)  
Lower Yukon School District  
Kwikpak Fisheries



# City of Emmonak

P.O. Box 9, Emmonak, Alaska 99581  
(907) 949-1227 • (907) 949-1249 • Fax (907) 949-1926  
email: emkcity@gmail.com

## CITY OF EMMONAK

### DECLARATION OF A PUBLIC HEALTH EMERGENCY

#### RESOLUTION NO. 20-04

**WHEREAS:** Coronavirus Disease 2019 (COVID-19) is a respiratory disease that can result in serious illness or death and is caused by the SARS-Cov-2 virus, a new strain of the coronavirus that has not been previously identified in humans and is easily transmittable person to person; and

**WHEREAS:** on March 11, 2020, the World Health Organization (WHO) declared that the outbreak of COVID-19 was a global pandemic; and

**WHEREAS:** on March 13, 2020, the President of the United States declared a national emergency in response to the pandemic; and

**WHEREAS:** on March 11, 2020 the Governor for the State of Alaska declared a Public Health Disaster Emergency as a result of COVID-19; and

**WHEREAS:** the WHO, the United States Government, and the Governor all advise that COVID-19 is highly contagious and presents a serious health risk to Americans, including severe illness and death; and

**WHEREAS:** the Commissioner of the Alaska Department of Health and Social Services has certified that it is highly probable that an outbreak of COVID-19 will occur in Alaska in the near future within the definition of "disaster" as codified at Alaska Statute 26.23.900(2)(E); and

**WHEREAS:** as of March 19, 2020, twelve (12) cases of COVID-19 have been identified in Alaska; and

**WHEREAS:** a proactive approach must be taken by both individuals and communities to slow the rate of infection to reduce the negative impact on our health care system; and

**WHEREAS:** the City Manager has determined that there is high likelihood that residents of Emmonak will be affected by COVID-19; and

**WHEREAS:** Section 8.10.020 of the Emmonak City Code allows for the City Council to declare an emergency based upon assessments by the City Manager and the declaration by the office of the Governor; and

**WHEREAS:** the public health information reviewed by the City and the declarations of the WHO, the United States, and the State of Alaska meet the requirements for an emergency declaration pursuant to Code Section 8.10.020; and

**WHEREAS:** a declaration of a local Public Health Emergency will alert the public to the seriousness of the risk as well as provide a mechanism for the City to coordinate its response and resources with local, State, and Federal agencies; and

**THEREFORE:** the Emmonak City Council declares a Public Health Emergency based on the threat of COVID-19 and authorizes the City Manager to act as the incident commander for the City, exercising all authority vested in the position by applicable local, State, and Federal law as well as directing the City Manager to procure services and contracts necessary to address this emergency as described in Chapter 8.10 of the City Code.

PASSED AND APPROVED THIS 23<sup>rd</sup> DAY March 2020.

Wilbur R Hootch

Wilbur Hootch, Mayor

SIGNED AND ATTESTED THIS 23<sup>rd</sup> DAY March 2020.

Lilly Westlock

Attest: Lilly Westlock, City Clerk

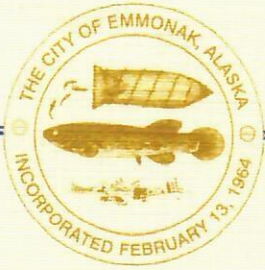

# City of Emmonak

P.O. Box 9, Emmonak, Alaska 99581  
(907) 949-1227 • (907) 949-1249 • Fax (907) 949-1926  
email: emkcity@gmail.com

## **CITY OF EMMONAK Resolution No. 2020-05**

### **A RESOLUTION OF THE EMMONAK CITY COUNCIL SEEKING FUNDING FROM THE STATE OF ALASKA AND FEDERAL GOVERNMENT FOR WATER AND SEWER SYSTEM REPAIRS AND SERVICES AND HEATING FUEL.**

**WHEREAS:** on March 23<sup>rd</sup>, 2020, the Emmonak City Council declared a Public Health Emergency because of Coronavirus Disease 2019 (COVID-19) pursuant to Section 8.10.020 of the City Code; and

**WHEREAS:** Section 8.10.040 of the City Code gives the City Manager emergency procurement powers; and

**WHEREAS:** the United States Centers for Disease Control and Prevention (CDC) advises that one of the most effective ways to protect yourself from contracting COVID-19 is to clean and wash your hands using soap and water; and

**WHEREAS:** the City provides water and sewer services to residents through a City-owned water and sewer utility as described in City Code Chapter 13.08; and

**WHEREAS:** during this Public Health Emergency, the City plans to keep the water plant and Community Washeteria operational so that residents can continue to practice good hygiene during this critical time; and

**WHEREAS:** City Code allows for the City to shut off water and sewer service for non-payment and require payment of delinquent amounts before water and sewer is reconnected; and

**WHEREAS:** until the current Public Health Emergency ends, the City will not shut off water or sewer services for non-payment and will not require payment of delinquent amounts before service is reconnected; and

**WHEREAS:** the residents are required to maintain water and sewer lines from the outside wall of the consumer's home while the City maintains all other portions of the lines; and

**WHEREAS:** certain repairs are necessary in order to reconnect homes that have been disconnected due to nonpayment and also to maintain connections for homes currently connected to the water and sewer system; and

**WHEREAS:** new units of housing were recently built in the City but have not been connected to the water and sewer system because the cost of connection is prohibitive; and

**WHEREAS:** other homes within the City are not currently connected to the water and sewer system; and

**WHEREAS:** the City has identified 34 homes that either need connections to the water and sewer system or that require major repairs to the lines; and

**WHEREAS:** using estimates from the Alaska Native Tribal Health Consortium, the City calculates the cost of connecting these 34 homes at \$4,284,000; and

**WHEREAS:** residents need access to clean water in order to follow the CDC guidelines to protect themselves and the community from COVID-19; and

**WHEREAS:** the City wishes to contract with a plumbing company and/or a construction firm to repair lines, repair water and sewer infrastructure, and reconnect homes that were disconnected for non-payment; and

**WHEREAS:** funds for these projects and repairs typically comes from payments from the consumer as well as grant funding from State and Federal sources; and

**WHEREAS:** the amount of outstanding water and sewer delinquent payments for homes that have already been disconnected from service is over \$7,000; and

**WHEREAS:** the City does not have the funds to undertake this work without State or Federal assistance; and

**WHEREAS:** the City does not have sufficient funds to pay for infrastructure projects to connect the housing units that are currently not connected to the water and sewer system; and

**WHEREAS:** the City does not have sufficient funds to maintain the water and sewer system without regular payments from customers; and

**WHEREAS:** the City is also experiencing a critical fuel shortage due to extended cold weather this winter; and

**WHEREAS:** in order to operate critical infrastructure, including the water and sewer system and Community Washeteria, the City requires an additional 20,000 gallons of heating fuel to get through the winter season; and

**WHEREAS:** the current cost of heating fuel is \$3.60 per gallon; and

**WHEREAS:** the City does not have the \$72,000 for the heating fuel it will need to keep critical services running; and

**WHEREAS:** these repairs, connections, and related heating fuel are critical to the health and safety of residents, especially in light of the CDC recommendations, during this Public Health Emergency; and

**WHEREAS:** both the State and Federal declarations provide for emergency funding to address this Public Health Emergency; and

**NOW THEREFORE BE IT RESOLVED:** the Emmonak City Council formally requests State and Federal funding related to this Public Health Emergency to fill the gaps in funding caused by nonpayment by customers, fund repairs to the water and sewer system, fund infrastructure projects, and fund the purchase of 20,000 of heating fuel to ensure all residents of Emmonak have access to critical water and sewer services for hygiene.

PASSED AND APPROVED THIS 23<sup>rd</sup> DAY March 2020.



Wilbur Hootch, Mayor

SIGNED AND ATTESTED THIS 23<sup>rd</sup> DAY March 2020.

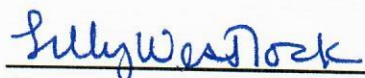

Attest: Lilly Westlock, City Clerk

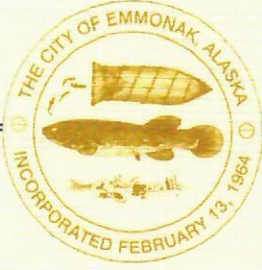

# City of Emmonak

P.O. Box 9, Emmonak, Alaska 99581  
(907) 949-1227 • (907) 949-1249 • Fax (907) 949-1926  
email: emkcity@gmail.com

## CITY OF EMMONAK

### TRAVEL ADVISORY DECLARATION

#### RESOLUTION 20-06

**WHEREAS:** Coronavirus Disease 2019 (COVID-19) is a respiratory disease that can result in serious illness or death and is caused by the SARS-Cov-2 virus, a new strain of the coronavirus that has not been previously identified in humans and is easily transmittable person to person; and

**WHEREAS:** on March 11, 2020, the World Health Organization (WHO) declared that the outbreak of COVID-19 was a global pandemic; and

**WHEREAS:** on March 13, 2020, the President of the United States declared a national emergency in response to the pandemic; and

**WHEREAS:** on March 11, 2020 the Governor for the State of Alaska declared a Public Health Disaster Emergency as a result of COVID-19; and

**WHEREAS:** on March 23<sup>rd</sup>, 2020, the City declared a Public Health Emergency related to COVID-19; and

**WHEREAS:** the WHO, the United States Government, and the Governor all advise that COVID-19 is highly contagious and presents a serious health risk to Americans, including severe illness and death; and

**WHEREAS:** on March 15, 2020, the State of Alaska issued a travel advisory (COVID-19 HEALTH Alert) asking all Alaskans returning from travel outside of Alaska to self-quarantine (stay at home) for 14 days upon their return home and monitor themselves for signs of COVID-19; and

**WHEREAS:** symptoms of COVID-19 include cough, fever, and/or difficulty breathing; and



**WHEREAS:** because of the City's remoteness and lack of a hospital, the City is at risk of a serious public health emergency if COVID-19 spreads in Emmonak; and

**WHEREAS:** travel allows the virus to spread from one community to another; and

**WHEREAS:** residents of Emmonak should stay home and quarantine themselves if they have any of these symptoms or have recently traveled outside of the State; and

**THEREFORE:** the Emmonak City Council advises all residents to follow the guidance issued by the State of Alaska regarding self-quarantine after travel and asks residents to restrict all non-essential or emergency travel in or out of Emmonak, including travel to neighboring communities, and limit visitors to Emmonak except in exigent circumstances, so that the spread of COVID-19 can be slowed.

PASSED AND APPROVED THIS 23<sup>rd</sup> DAY March 2020.

Wilbur Hootch

Wilbur Hootch, Mayor

SIGNED AND ATTESTED THIS 23<sup>rd</sup> DAY March 2020.

Lilly Westlock

Attest: Lilly Westlock, City Clerk

# PUBLIC NOTICE FROM CITY OF EMMONAK CORONAVIRUS (COVID – 19) PANDEMIC

\*\*\*\*\*

- COVID-19 IS A RESPIRATORY VIRUS THAT CAN RESULT IN SERIOUS ILLNESS OR DEATH. THE STATE OF ALASKA DECLARED A PUBLIC HEALTH EMERGENCY RELATED TO COVID-19.
- COVID-19 IS EASILY BE SPREAD FROM PERSON TO PERSON. SYMPTOMS INCLUDE COUGH, CONGESTION, AND FEVER. IF YOU HAVE THESE SYMPTOMS OR ARE EXPOSED TO THE VIRUS, STAY HOME.
- THE BEST WAY TO PREVENT INFECTION IS TO VIGOROUSLY WASH YOUR HANDS AND SANITIZE FREQUENTLY TOUCHED SURFACES.
- TO PREVENT THE SPREAD OF INFECTION, THE CITY IS CLOSING THE EMMONAK COMMUNITY COMPLEX TO MEETINGS AND PUBLIC GATHERINGS, INCLUDING BINGO AND PULL TAB OPERATIONS, UNTIL FURTHER NOTICE. THE WASHETERIA WILL REMAIN ON LIMITED HOURS TO ALLOW FOR ENHANCED CLEANING.
- PUBLIC MEETINGS OF MORE THAN 10 PEOPLE SHOULD BE CANCELLED AND RESIDENTS SHOULD PRACTICE SOCIAL DISTANCING AS DESCRIBED BY THE U.S. CDC TO PREVENT THE SPREAD OF THE VIRUS.
- FOLLOWING THE STATE’S GUIDANCE, ANYONE WHO RECENTLY TRAVELED OUTSIDE OF ALASKA IS ASKED TO REMAIN AT HOME AND SELF-QUARRANTINE FOR 14 DAYS. RESIDENTS ARE ASKED TO LIMIT ALL TRAVEL IN AND OUT OF EMMONAK TO SLOW THE SPREAD OF THE VIRUS.



# **\*\*COVID-19 HEALTH ALERT\*\***

Issued March 15, 2020

By: Dr. Anne Zink, Chief Medical Officer, State of Alaska

DHSS strongly advises that all Alaskans read and comply with the following guidance for returning travelers:

1. **Higher Risk:** For travelers returning within 14 days from the time you left an area with *widespread, ongoing community spread* such as Europe, China and other countries (i.e., a [CDC Level 3 Travel Health Notice Area](#)) you should:
  - Stay home and avoid contact with other household members.
  - Contact your employer and do not go to work or school for this 14-day period after you return.
  - [CDC Level 3 Travel Health Notice Area](#)
    - China, Iran, South Korea, Austria, Belgium, Czech Republic, Denmark, Estonia, Finland, France, Germany, Greece, Hungary, Iceland, Italy, Latvia, Liechtenstein, Lithuania, Luxembourg, Malta, Netherlands, Norway, Poland, Portugal, Slovakia, Slovenia, Spain, Sweden, Switzerland, Monaco, San Marino, Vatican City.
2. **Medium Risk:** For travelers returning within 14 days from outside of Alaska (including the rest of the United States) you should:
  - Discuss your work situation with your employer before returning to work.
  - Minimize contact with people as much as possible, self-monitor and practice social distancing.
  - This may mean not going to work or school if you cannot safely be distanced from others – especially if you traveled in a location where community transmission is occurring.

## **Health Guidance for Returning Travelers in the Higher and Medium Risk Groups**

1. Take your temperature with a thermometer two times a day and monitor for fever. Also watch for cough or trouble breathing.
2. Do not take mass transportation during the time you are practicing social distancing.
3. Avoid crowded places (such as shopping centers and movie theaters) and limit your activities in public.
4. Keep your distance from others (about 6 feet or 2 meters).
5. If you get sick with fever (>100.3°F), cough, or shortness of breath, please call your health care provider.
6. If you seek medical care for other reasons, such as dialysis, call ahead to your doctor and tell them about your recent travel.

All Alaskans should follow previous guidance including regular hand washing, cleaning surfaces and avoiding large gatherings ([March 13 COVID-19 Health Alert: Recommendations for Keeping Communities Safe](#)).

This is not a mandate. This guidance is based on CDC's guidance, which can be found here:

[www.cdc.gov/coronavirus/2019-ncov/](http://www.cdc.gov/coronavirus/2019-ncov/)  
State of Alaska COVID-19 Health Alert 005

**CITY OF EMMONAK**  
**COVID – 19**  
**DOCUMENT 1**

1. This is a major disclosure of Emergency Declaration of related to Corona Virus COVID – 19 without heating fuel at the Water Treatment Plant Water/Sewer system will close
2. City of Emmonak has less then 14,000 gallons heating fuel
3. Emmonak Corporation has less then 13,000 gallons 887 residents. 242 homes estimate 60,000 gallons heating fuel
4. Nunam Iqua is low in heating fuel City of Emmonak will work closely with entities that have large capacity tank farms which includes following for quickest response towards emergency
  - A. Alaska Village Electric Co-operative (AVEC)  
Anchorage, Alaska
  - B. Yukon Region – School District  
Lower Yukon School District Mountain Village, Alaska
  - C. Emmonak, Kwik-Pak Fisheries Emmonak, Alaska
  - D. Fly in heating fuel air lift, Anchorage – Emmonak –  
Anchorage by Air Cargo freight shippers Everts, Lynden  
or Northern Air Cargo

This emergency is imminent the support is most urgent.

**2020 WINTER SEASON IS EXTREMALLY COLD CAUSING  
HEATING FUEL SHORTAGES**

At the time City ordered heating fuel June 11, 2019 City Tank Farm had 16,817-gallon heating fuel and Water Treatment Plant had 17,000 gallons, total inventory June 30, 2019, 33,817 gallons by the end of October 18, 2019 the City had enough room to order additional 46,585 which was then determined adequate for the season 2019-2020.

Current to date the persistent cold weather has proven our fuel inventory is not adequate to meet the demand. City is short of heating fuel until the next barge arriving. Currently City inventory of heating fuel #1 is less 14,000 gallons it means City operations for the Administrative office, Public Safety Building, Public Works Dept., Sauna/Washeteria and most importantly Water Treatment Plant will be out of heating fuel by April 2020.

Emmonak Corporation the current fuel retail operations has less 13,000 gallons limiting retail to the elder's group and disabled residents.

They project fuel sales will end before barge season begins Emmonak residents are requested get their heating fuel from Alakanuk, Alaska.

Nunam Iqua (Sheldon Point) is running out of heating fuel as well.

Because of the extreme weather conditions shortage of heating fuel is accruing. City Council recommends through Declaration of a Public Health Emergency Resolution NO. 20 – 04 and Resolution No. 20 -05 for State and Federal Government provide relief emergency steps in order to safe guard health and well-being of 850 plus people of Emmonak.

In the community of Emmonak, Alaska Village Electric Co-operative (AVEC) has 550,000 capacity tank farm located mid-center of the community of Emmonak. AVEC is the first and most important entity

that is available for response for Emmonak people. For shortage of fuel second entity is Lower Yukon School District who also has large Tank Farm.

While there might not be enough heating fuel for everyone the third response entity would be State and Federal Government to fly in by Air Cargo Freight. We appreciate the State of Alaska and Federal Government for considering Public Assistance.

**PROVIDED THE INFORMATION VERIFIES ESTIMATE COSTS**

2019-2020 fall and winter subzero temperatures forced the Yukon Delta region communities to escalate the use of their Heating Fuel inventory.

Both the City of Emmonak and Emmonak Corporation ordered enough Heating Fuel for 2019-2020m the unpredictable and very cold winter cause escalation and use of Heating Fuel.

City of Emmonak Public Services Water Treatment Plant and Community Washeteria are lacking and short of Heating Fuel, 14,000 gallons remaining, 350 gallons per/day is used on all departments, 40 days left before running out.

In order to survive 2019-2020 season, the City of Emmonak need 20,000 gallons to be on the safe side. \$3.60 @ 20,000 gallons equal \$72,000. City is cash starved and is in critical cash flow.

Proposed estimate prepared by Martin B. Moore, Sr., City Manager & Darlene Westlock Accounts Receivable and Payable.

Fax to: Martin Moore 907-949-1926 phone: 1227

Quote Number: **109105**

Date Quoted: 06/10/19

Date Issued: 06/11/19

# Crowley Fuels LLC.

PLEASE SEND INQUIRIES OR REMITTANCE TO:  
201 Arctic Slope Avenue, Anchorage, AK 99518  
(907) 777-5505 1-800-977-9771 FAX (907) 777-5553

Please Note: THIS IS A QUOTATION ONLY!

PO No: --

Required by: Spring  
Fed Registration:  
State QD:

City of Emmonak  
P O BOX 9  
Emmonak, AK, 99581

Payment Terms:  
Prepayment pending credit approval.

Deliver to: City of Emmonak  
At: Emmonak

Package	Product	Quantity	Fed	Sta	L	Price	Total	F	S
BULK	HF#1	35000	0.001	0.009	X	2.9326	\$102,641.00	2	6 ~
BULK	UNL GAS	3000	0.184	0.059	X	2.9885	\$8,965.50	0	24 ~

9-18-19

tod Tikken  
9-18-19

ATT TVEVER -  
1 800-977-9771

Quantity total 38000      Subtotal \$111,606.50  
Local Tax 0.0% \$0.00  
**TOTAL \$111,606.50**

Martin Moore  
1. Prices are firm for Spring delivery. Customer agrees to take all gallons ordered.  
2. Pricing is based on above quantities and does not include fees for trucking, wharfage, storage, or other ancillary charges applied to delivery.  
3. Payment terms: Subject to credit approval; payment due upon invoice. Crowley accepts ACH, wire transfers, checks, and cash on commercial accounts  
4. The attached Terms and Conditions are applicable.  
5. Taxes are as indicated above and may be subject to change based upon regulatory certifications or exemptions.  
6. Offer good until close of business, 06/11/19.  
To accept this offer please sign, date, fax or email to my attention.  
Thank you for the opportunity to provide our services.  
Best regards, Randy Breaux 907.777.5537; Fax: 907-777-5550

A 33,975.00  
MAY 9-10-19

ACCEPTED BY BUYER Martin Moore TITLE City Manager DATE 6-11-2019

ACCEPTED BY SELLER Randy Breaux TITLE Manager, Sales and Marketing DATE 06/11/19

Errors in price, extension and addition subject to correction. Marine Standard Terms and Conditions are incorporated and made part thereof. Quantity is in US Gallons unless otherwise noted.



Fax to:



# Crowley Fuels LLC.

Quote Number: **109193**

Date Quoted: 09/18/19

Date Issued: 09/18/19

PLEASE SEND INQUIRIES OR REMITTANCE TO:  
201 Arctic Slope Avenue, Anchorage, AK 99518  
(907) 777-5505 1-800-977-9771 FAX (907) 777-5550

Please Note: THIS IS A QUOTATION ONLY!

PO No: --

Required by: FALL

Fed Registration:

State QD:

City Of Emmonak  
P O BOX 9  
Emmonak, AK, 99581

Payment Terms:  
Net 30 days unless otherwise noted.

Deliver to: City Of Emmonak  
At: Emmonak

Package	Product	Quantity	Fed	Sta	L	Price	Total	F	S
BULK	HF#1	11585	0.001	0.009	X	2.9326	\$33,974.17	2	6 ~

Quantity total	11585	Subtotal	\$33,974.17
		Local Tax 0.%	\$0.00
		<b>TOTAL</b>	<b>\$33,974.17</b>

Martin Moore

- Prices are firm for Spring delivery. Customer agrees to take all gallons ordered.
- Pricing is based on above quantities and does not include fees for trucking, wharfage, storage, or other ancillary charges applied to delivery.
- Payment terms: Subject to credit approval; payment due upon invoice. Crowley accepts ACH, wire transfers, checks, and cash on commercial accounts
- The attached Terms and Conditions are applicable.
- Taxes are as indicated above and may be subject to change based upon regulatory certifications or exemptions.
- Offer good until close of business, 09/18/19.

To accept this offer please sign, date, fax or email to my attention.  
Thank you for the opportunity to provide our services.  
Best regards, Todd Tikiun 907.777.5569; Fax: 907-777-5550

ACCEPTED BY BUYER Martin Moore TITLE City Manager DATE 9-18-19  
ACCEPTED BY SELLER Todd Tikiun TITLE Account Executive DATE 09/18/19

Errors in price, extension and addition subject to correction. Marine Standard Terms and Conditions are incorporated and made part thereof. Quantity is in US Gallons unless otherwise noted.

**CITY OF EMMONAK**  
**COVID – 19**  
**DOCUMENT 2**

1. Connect Six AVCP RHA new homes to Water/Sewer Service lines at 840,000
2. Support Village Safe Water funding of main infrastructure Water/Sewer main
3. 2019 – 2020 Four homes have burned down. New homes are in process of being rebuild, their new Water/Sewer services lines are estimate at \$560,000

## **2020 COVID – 19 CONCERN**

The City Council adopted Resolution 2020 – 05 in hopes that six Water/Sewer service line funding of \$140,000 each would be considered as soon as possible. In the amount of total \$840,000.

The Water & Sewer main is already in the plan with Village Safe Water and estimated to cost over \$900,000.

Accelerating the plan, and the funding for the AVCP Water Sewer Service lines and AVCP Construction of the Water and Sewer main to AVCP five homes is very critical.

COVID – 19 Resolution No. 2020 -0 5 City of Emmonak considers Water and Sewer Service lines to connection to be very urgent homes of five families.

The five homes are identified with yellow high lite marking and located at Emmonak Road on the eastside of 22 units of old AVCP housing.

The five new homes have no water and sewer service lines connected to them. But the families are living in them disposing human waste near their home or somewhere else this action has been recommended to AVCP RHA to be unhealthy circumstances to 22 units of housing nearby them at Emmonak Road where family members are multiply.

Today with COVID – 19 Potable Water & Sewer System connection to five homes extraordinarily urgent, your fullest consideration is appreciated.

**NEW AVCP HOUSING NEED COMPLETELY NEW WATER/SEWER SERVICE LINES**

JOSEPH AUGUSTINE  
KIMBERLY MOORE  
LOIS ISAAC  
DARLENE WESTLOCK  
JACANITA TUCKER  
BART AGATHLUK, JR.

**6 HOMES @ \$140,000.00 = \$840,000.00**

LIST OF HOMES BURN DOWN BEING REBUILT WILL NEED SERVICE LINES

BRIAN AGWIAK  
IDA AGATHLUK  
HERBURT LEOPOLD  
EVELYN MOORE

**4 HOMES @ \$140,000 = \$560,000**

- CONSTRUCTION NOTES**
1. THE HIGH WATER ELEVATION (HWE) SHOWN AT CITY HALL HAS BEEN SET BY USACE AS THE 100-YEAR FLOOD LEVEL. ELEVATION: THE HIGH WATER IS EQUIVALENT TO 20.7' NAVD.
  2. FINISH FLOOR ELEVATION SHALL BE 2' MIN ABOVE THE BASE FLOOD ELEVATION.

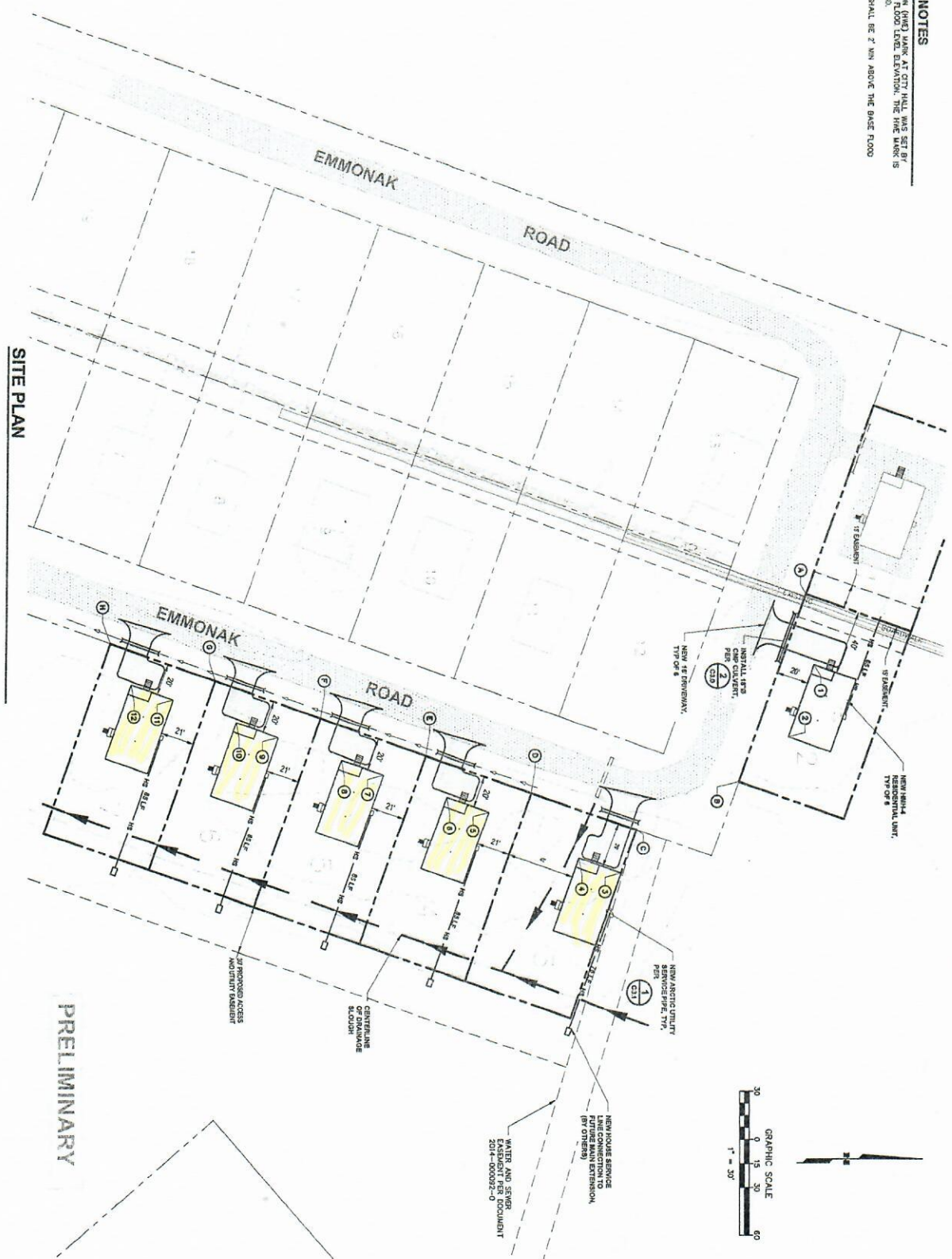

**SITE PLAN**

**PRELIMINARY**

SCALE	AS SHOWN
GRIDED BY	DC
DRAWN BY	CS
CHECKED BY	DC/M
DATE	11/05/14
DWG. NO.	1000.06
SHEET NUMBER	C1.0

**AVCP RHA 2015 VILLAGES**  
**EMMONAK**  
**SITE PLAN**

**ICG**  
 Inc  
 250 H Street  
 Anchorage, AK 99501  
 P (907) 243-6985  
 F (907) 243-6629  
 www.icgak.com



**AVCP RHA**  
 Regional Housing  
 Authority  
 405 Primmgen Rd.  
 Bethel, Alaska 99559  
 (907) 543-3121

NO.	DATE	BY	REVISION

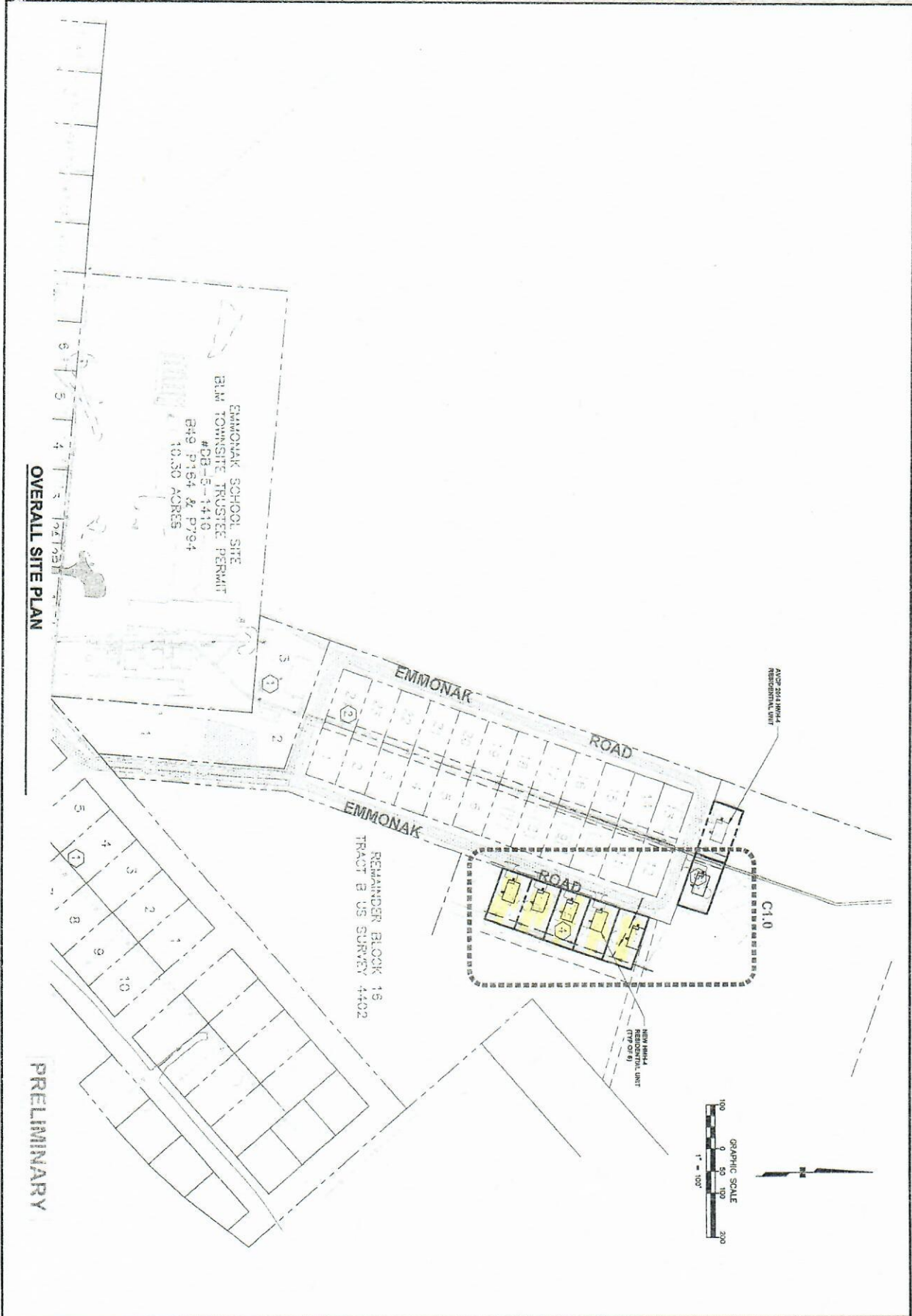

SCALE	AS SHOWN
DESIGNED BY	DC
DRAWN BY	CS
CHECKED BY	DD/MH
DATE	1/8/14
PAC. NO.	1000.06
SHEET NUMBER	1000.06

AVCPRHA 2015 VILLAGES  
 EMMONAK  
 OVERALL SITE PLAN

**ICG**  
 Inc  
 250 H Street  
 Anchorage, AK 99501  
 P (907) 243-8885  
 F (907) 243-3629  
 www.icgax.com



AVCPRHA  
 Regional Housing  
 Authority  
 405 Paumigan Rd.  
 Bethel, Alaska 99559  
 (907) 543-3121

NO.	DATE	BY	REVISION

### GENERAL NOTES

- EXISTING GROUND CONDITIONS SHOWN ARE BASED ON A TOPOGRAPHIC SURVEY PERFORMED MAY 2014 BY LSI SURVEY. CONSTRUCTION SHALL VERIFY SITE CONDITIONS.
- CONTRACTOR SHALL OBTAIN ALL PERMITS, IF APPLICABLE, PRIOR TO ANY EXCAVATION ACTIVITIES.
- LOCATIONS OF EXISTING UTILITIES ARE APPROXIMATE. THE CONTRACTOR SHALL VERIFY LOCATIONS EXCAVATION. ALL UTILITY LOCATES PRIOR TO BEGINNING CONSTRUCTION. EXERCISE CAUTION DURING EXCAVATION.
- VERIFY HEIGHTS AND LOCATIONS OF ALL UTILITY CONNECTIONS POINTS PRIOR TO INSTALLING PIPE.
- RENDERINGS SHOWN ARE TO PREPARE, FLOW LINE OR FINISH GRADE SURFACE UNLESS NOTED OTHERWISE.
- DIMENSIONS SHOWN ARE TO EDGE OF PROPERTY LINE, EDGE OF GRAVE, PAV. OR EXTERIOR FACE OF BUILDING UNLESS NOTED OTHERWISE.

### CONSTRUCTION NOTES:

- THE CONTRACTOR SHALL PROVIDE RECORD SURVEY NOTES OF ALL IMPROVEMENTS ALONG WITH THE RED LINED CONSTRUCTION DRAWINGS UPON COMPLETION OF CONSTRUCTION.
- IT SHALL BE THE CONTRACTOR'S RESPONSIBILITY TO FIELD VERIFY THE HORIZONTAL AND VERTICAL LOCATION OF ALL EXISTING UTILITIES AND TO RECORD ANY CHANGES/OBSERVANCES ON THE RECORD DRAWINGS. SEE RECORD DRAWING NOTES.
- SIGNALING SHALL BE THE RESPONSIBILITY OF THE CONTRACTOR THAT PENETRATES THE GROUND WATER SURFACE OR ARE SUBJECT TO FLOODING.
- CONTRACTOR SHALL COORDINATE ALL UTILITY WORK WITH THE UTILITY PROVIDERS AS REQUIRED.

### PROJECT RESTORATION NOTES:

- ALL AREAS DISTURBED BY CONSTRUCTION SHALL BE RESTORED TO PRE-CONSTRUCTION CONDITION OR AS DIRECTED BY THE OWNER. CONSTRUCTION SHALL EXERCISE DUE CARE TO AVOID DISTURBING AREAS OUTSIDE OF WORK LIMITS.
- DISTURBED AREAS OUTSIDE WORK LIMITS SHALL BE STABILIZED IN ACCORDANCE WITH THE PLANS.
- ALL DISTURBED AREAS OR SLOPES GREATER THAN 3:1 SHALL BE GRADED AND BROUGHT SEEDS AT A RATE OF 4 LBS PER 1000 SF WITH THE FOLLOWING SEED MIX:  
 ARCHARD RED FESCUE (FESTUCA RUBRA) - 60%  
 GRASSLAND UPER BULBDOGS (POA ALPINA) - 20%  
 NORTHERN TUFTED HARRISGRASS (DESCHAMPIA CESTRIFOLIA) - 10%

### ABBREVIATIONS

APPROX	APPROXIMATE	HHS	HEATED GUYOL SUPPLY
BLU	BALL VALVE	HMH-4	4 BEDROOM HOME PROGRAM
BUP	BURIED UTILITY	HMP	HOME MORTGAGE/HIGH POINT
CHP	CORRUGATED METAL PIPE	HP	HOUSE SERVICE
CORP	CORPORATION	H5	HOUSE SERVICE
CL	CENTER LINE	INV	INVERT ELEVATION
DI	DIAMETER	LF	LINEAR FEET
DIR	DEPARTMENT OF NATURAL RESOURCES	MAX	MAXIMUM
D/W	DRIVEWAY	ME	MATCH EXISTING
E	EACH	MH	MANHOLE
ELEV	ELEVATION	MIN	MINIMUM
EX	EXISTING	NC	NOT IN CONTRACT
EXIST	EXISTING	PF	PEABODY FACTOR
F	FANBREKET	R	RIGHT OF WAY
FF	FINISH FLOOR	ROW	RIGHT OF WAY
FG	FINISH GRADE	SEC	SECOND
FL	FLOW LINE	SSCD	SANITARY SEWER CLEAN-OUT
FM	FINISH MAIN	SSMH	SANITARY SEWER MANHOLE
FLY	FORCE MAIN	SS	SEWER SERVICE
FLL	FINISH LINE	STA	STATION
GAL	GALLON	STA	STATION
GALV	GALVANIZED	STM	STANDARD MAIN
GB	GRADE BREAK	TP	TEST POINT
GPD	GALLONS PER DAY	WS	WATER SERVICE
GPM	GALLONS PER MINUTE		
HOPE	HIGH DENSITY POLYETHYLENE		
HOR	HEATED GUYOL RETURN		

### LEGEND

PROPOSED	EXISTING	DESCRIPTION
---	---	PROPERTY LINE
---	---	EXISTING LINE
---	---	MAJOR CONTROL
---	---	MINOR CONTROL
---	---	BLOCK NUMBER
---	---	LOT NUMBER
---	---	FENCE LINE
---	---	DRAINAGE SWALE
---	---	100 YEAR FLOOD BOUNDARY
---	---	WATER BODY (NEARBY)
---	---	BRUSH LINE
---	---	EDGE OF CUT SLOPE
---	---	TOE OF FILL SLOPE
---	---	GRAVEL ROAD/PAD
---	---	BOONWALK
---	---	OVERHEAD UTILITY LINE
---	---	UNDERGROUND UTILITY LINE
---	---	SEWER MAIN LINE
---	---	SEWER SERVICE LINE
---	---	SEWER FORCE MAIN
---	---	VACUUM SEWER
---	---	WATER MAIN LINE
---	---	WATER SERVICE LINE
---	---	WATER & SEWER SERVICE
---	---	FILED LINE
---	---	OLVERT
---	---	SEPTIC TANK
---	---	WATER WELL
---	---	CLEARCUT
---	---	FIRE HYDRANT
---	---	SEWER MAN HOLE
---	---	WATER VALVE
---	---	TEST HOLE
---	---	UTILITY POLE WITH GUY WIRE

AVCPRHA 2015 VILLAGES  
 EMMONAK

LEGEND, ABBREVIATION, NOTES

SCALE	AS SHOWN
DRAWN BY	DC
CHECKED BY	CS
DATE	11/05/14
PLT NO.	1500/2

G1.0 of

ICG  
 Intergraph Inc  
 250 H Street  
 Anchorage, AK 99501  
 Phone: (907) 243-5626  
 Fax: (907) 243-5626  
 www.icgak.com



AVCPRHA  
 Regional Housing  
 Authority  
 405 Peatmigan Rd.  
 Bethel, Alaska 99559  
 (907) 543-3121

NO.	DATE	BY	REVISION

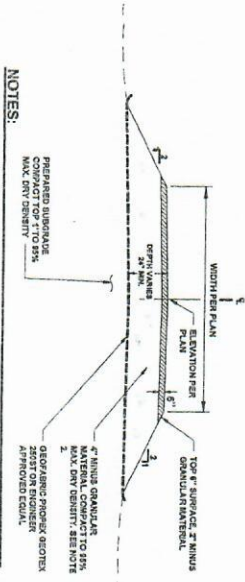

**1** PAD AND DRIVEWAY SECTION  
 C3.0 SCALE NOT TO SCALE

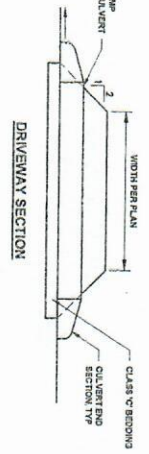

**2** TYPICAL DITCH SECTION  
 C3.0 SCALE NOT TO SCALE

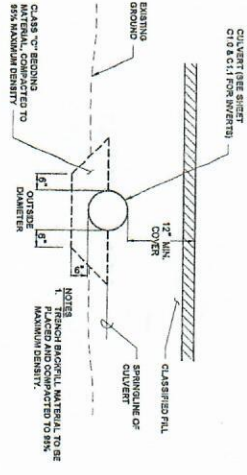

**3** CULVERT DETAILS  
 C3.0 SCALE NOT TO SCALE

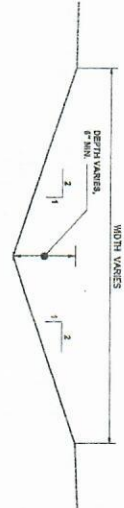

CULVERT SCHEDULE

LOT No.	CULVERT SIZE (IN)	CULVERT LENGTH (FT)	IN INVERT IN (FT)	E INVERT OUT (FT)	END SECTION	RIPRAP OUTLET
LOT 2	18"	32'			2	NO
LOT 3	18"	32'			2	NO
LOT 4	18"	32'			2	NO
LOT 5	18"	32'			2	NO
LOT 6	18"	32'			2	NO
LOT 7	18"	32'			2	NO

**CULVERT INSTALLATION NOTES**  
 1. CULVERTS SHALL BE INSTALLED PER ALASKA DOT'S STANDARD DRAWING S-0122(M), TYPE C.  
 2. EXISTING UTILITIES SHALL BE MAINTAINED AND NOT REMOVED UNLESS OTHERWISE NOTED.  
 3. ALL CULVERTS SHALL BE INSTALLED WITH A MINIMUM OF 12' COVER.  
 4. ALL CULVERTS SHALL BE INSTALLED WITH A MINIMUM OF 4' GRANULAR MATERIAL ABOVE AND BELOW THE CULVERT.  
 5. ALL CULVERTS SHALL BE INSTALLED WITH A MINIMUM OF 10' GRANULAR MATERIAL TO THE EDGES OF THE DRIVEWAY WITHIN 10' OF THE DRIVEWAY.

SCALE	AS SHOWN
DESIGNED BY	DC
DRAWN BY	CS
CHECKED BY	DC/MH
DATE	11/20/14
DWG. NO.	1000.06
SHEET NUMBER	C3.0

AVCPRHA 2015 VILLAGES  
 EMMONAK  
 CIVIL DETAILS (1 OF 2)

**ICG**  
 Inc  
 250 H Street  
 Anchorage, AK 99501  
 P (907) 243-6699  
 F (907) 243-5629  
 www.icgak.com

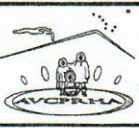

AVCPRHA  
 Regional Housing  
 Authority  
 405 Ptarmigan Rd.  
 Bethel, Alaska 99559  
 (907) 543-3121

NO.	DATE	BY	REVISION



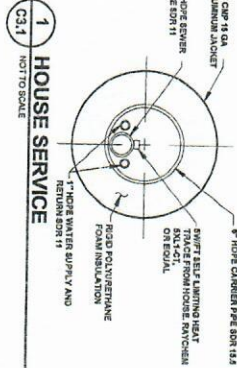

1 HOUSE SERVICE  
 NOT TO SCALE

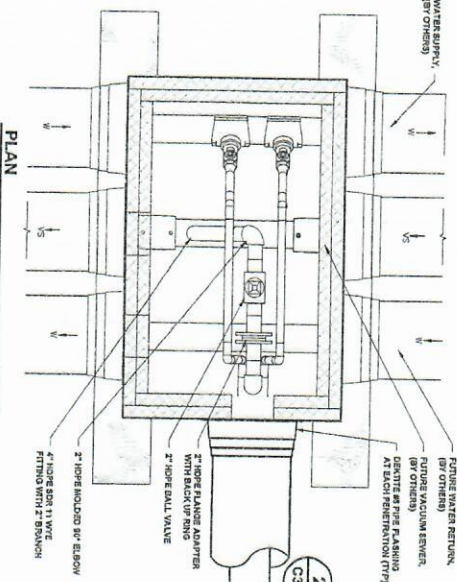

2 ADJUSTABLE PIPE STRAP DETAIL  
 NOT TO SCALE

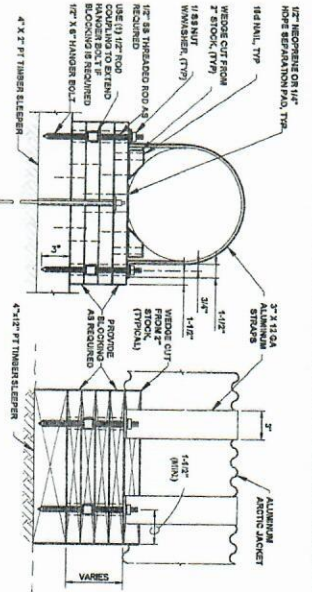

3 TYPICAL THRU SLEEPER ANCHOR DETAIL  
 NOT TO SCALE

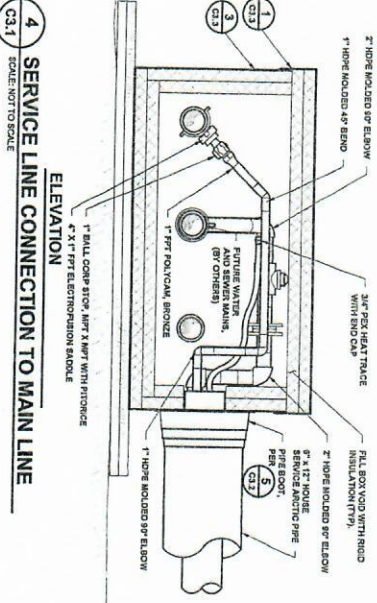

4 SERVICE LINE CONNECTION TO MAIN LINE  
 SCALE: NOT TO SCALE

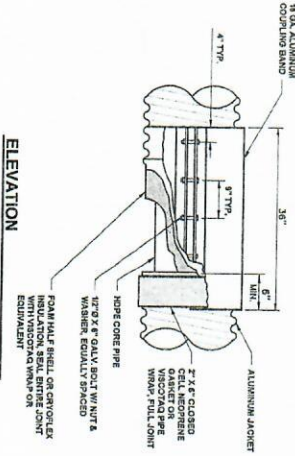

5 TYPICAL ARCTIC PIPE JOINT  
 NOT TO SCALE

NOTES:  
 1. INSURE THAT SLEETS TO PIPE WITH TAPERED ENDING DO NOT REMAIN IN CONTACT WITH THE PIPE.  
 2. CORE PIPES SHALL BE JOINED USING PUSHON TYPE COUPLERS.

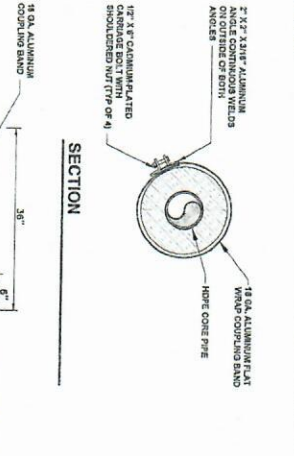

6 TYPICAL ANCHOR/SLEEPER SPACING PLAN  
 NOT TO SCALE

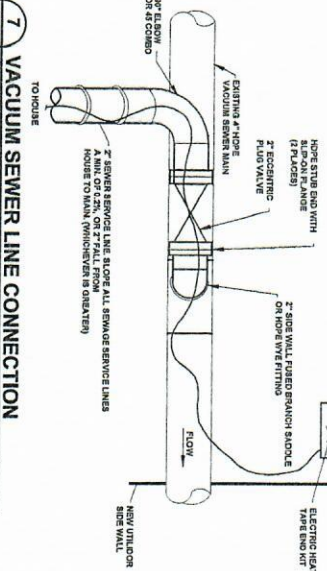

7 VACUUM SEWER LINE CONNECTION  
 NOT TO SCALE

**3** INTERIOR CIRCULATING WATER SERVICE MANIFOLD  
 C3.2 NOT TO SCALE

ITEM	QTY	SIZE	DESCRIPTION
1	1	1"	PUMP MANIFOLD, GUARDING ALL PUMP CIRCUITRY EQUIVALENT.
2	1	1"	FOOD BALL VALVE, CIBING 3709 SI-144
3	1	1"	NON-RETURN POLYMER VALVE
4	1	1"	TEE BRASS, T10 OR B3
5	1	1"	TEE BRASS, T10 OR B3
6	1	1"	90° ELBOW, T10 OR B3
7	1	1"	90° ELBOW, T10 OR B3
8	1	1"	NON-RETURN BRASS VALVE
9	1	1"	EXTENSION
10	1	1"	PIPE TYPHOGRAPH WALL AND INTERIOR

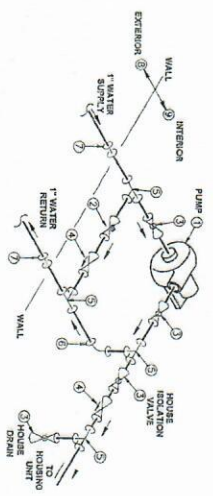

**1** PREFABRICATED SERVICE MANIFOLD  
 C3.2 SCALE NOT TO SCALE

- WATER NOTES:**
1. ALL WATER SERVICE MANIFOLD PIPING IS 1" DIA. 11 HOSE PIPE.
  2. TO SHUT OFF WATER SERVICE TO HOUSE, CLOSE AND LOCK SUPPLY AND RETURN VALVE.
  3. OPEN SPINNS VALVE TO CIRCULATE WATER.
  4. PREFABRICATED MANIFOLD ASSEMBLY SHALL BE PRESSURE TESTED BY MANUFACTURER TO 150 PSI.

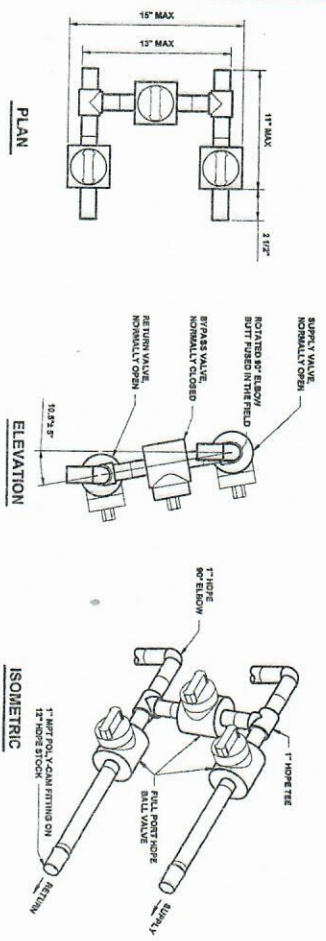

**4** HOUSE SERVICE CONNECTION DETAIL  
 C3.2 SCALE NOT TO SCALE

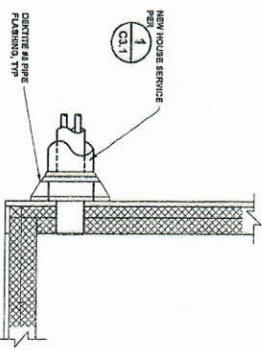

**2** VACUUM SEWER AND WATER SERVICE DETAIL  
 C3.2 NOT TO SCALE

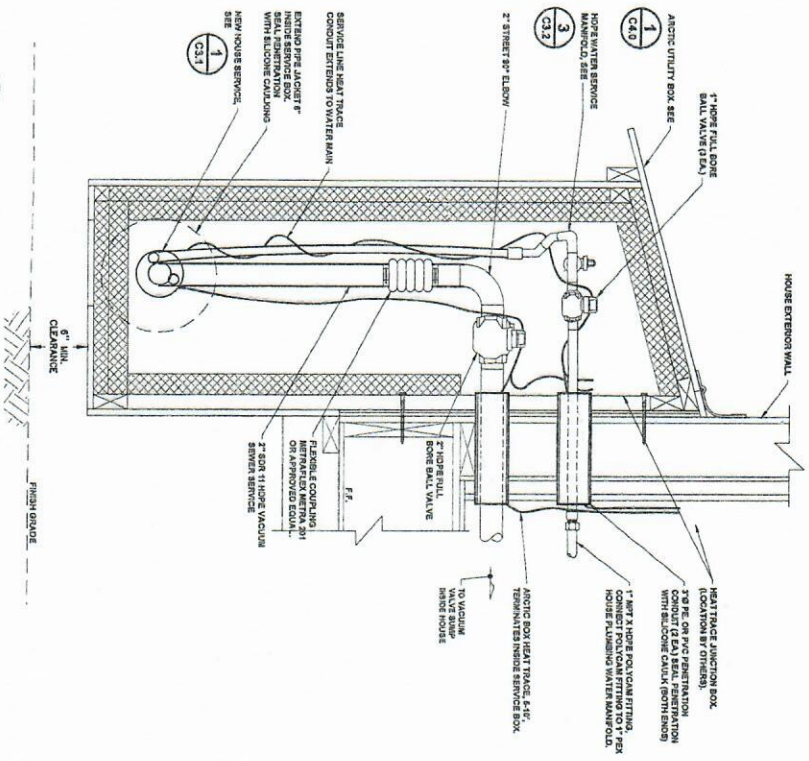

**5** SERVICE LINE ENTRY  
 C3.2 NOT TO SCALE

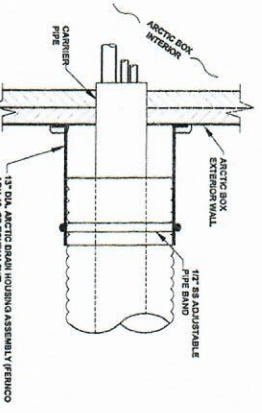

SCALE:	AS SHOWN
DESIGNED BY:	DC
DRAWN BY:	CS
CHECKED BY:	DC/M
DATE:	11/27/14
REV. NO.	1000.06
SHEET NUMBER:	C3.2

AVCPRHA 2015 VILLAGES  
 EMMONAK  
 HOUSE SERVICE  
 CONNECTION DETAILS

**ICG**  
 Intergraph Inc  
 250 H Street  
 Anchorage, AK 99501  
 P (907) 243-8985  
 F (907) 243-3635  
 www.icgall.com



AVCPRHA  
 Regional Housing  
 Authority  
 405 Pharrigan Rd.  
 Bethel, Alaska 99559  
 (907) 543-3121

NO.	DATE	BY	REVISION

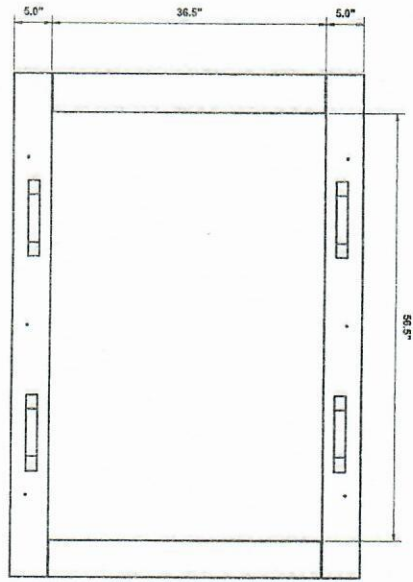

**2** TRIPLE LINE PLUMBING SERVICE LID FABRICATION  
 C3.3 SCALE: 1/4"=1'-0"

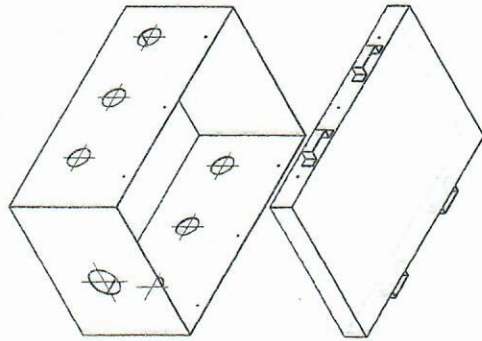

**2** TRIPLE LINE PLUMBING SERVICE FABRICATION ISOMETRIC  
 C3.3 SCALE: 1/4"=1'-0"

- NOTES:**
1. FABRICATE BOX FROM 6.125" X031 HXZ ALUMINIUM.
  2. ALL BOX JOINTS FORMED BY BENDING OR WELDED FULL LENGTH OF SEAM.
  3. PRE-DRILL (4) HOLES 2 OPPOSING SIDES WITH #2 DRILL.
  4. SECURE LID TO BOX WITH (4) 1/4" 4 SS SELF-TAPPING HEX HEAD SCREWS.
  5. PRE-DRILL (4) 1/4" Ø WEEP HOLES AT 8 INCHES FROM EACH CORNER OF BOX BOTTOM.
  6. THE PLUMBING SERVICE BOX CONTAINING THE RIGHT ANGLE HOSE VALVE SHALL BE 3" DEEP.
  7. HOLE SPACING MAY VARY DEPENDING ON EXISTING OR PROPOSED MAINLINE PIPE SPACING.

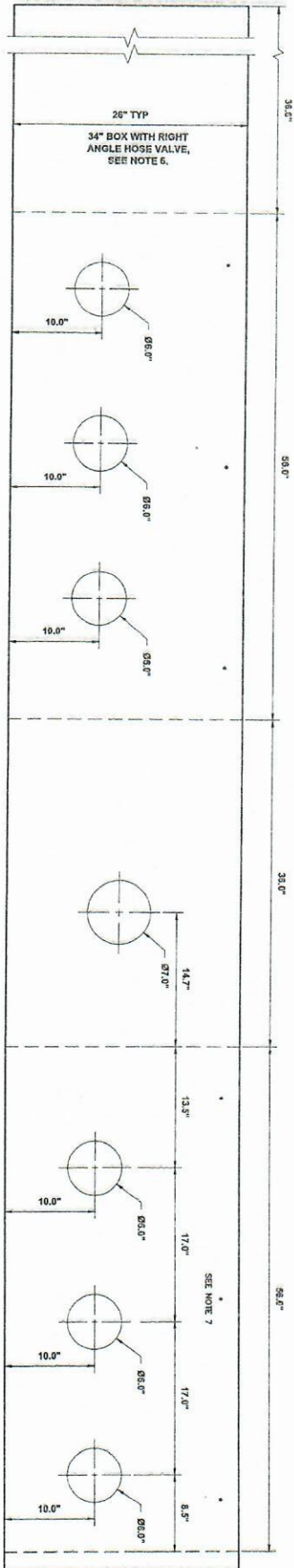

**3** TRIPLE LINE PLUMBING SERVICE BOX FABRICATION  
 C3.3 SCALE: 1/4"=1'-0"

NO.	DATE	BY	REVISION

AVCPRHA 2015 VILLAGES  
 EMMONAK  
 UTILIDOR BOX  
 FABRICATION DETAILS

**ICG**  
 Intertech Inc  
 250 H Street  
 Anchorage, AK 99501  
 P (907) 243-6985  
 F (907) 243-6629  
 www.icgat.com



AVCPRHA  
 Regional Housing  
 Authority  
 405 Palmign Rd.  
 Bethel, Alaska 99559  
 (907) 545-3121

C3.3  
 SHEET NUMBER



**CITY OF EMMONAK  
COVID – 19  
DOCUMENT 3**

1. 26 homes are located within Emmonak Townsite
2. At Emmonak Funding Resource are not available for these individuals
3. The individuals are within the perimeters of Water/Sewer infrastructure. Reconnection to Water/Sewer System is estimate \$123,000 each per home

## **REQUEST WATER/SEWER DISCONNECT TO INDIVIDUALS**

These 26 individuals have homes within the City limits in Emmonak Town-Site they have honey buckets services only considered by the City Council the endangerment to health and wellbeing near and around other family members in town.

The three page document dated October 1, 2019 from the State of Alaska, Department of Environmental Conservation estimates the cost to be \$123,000 each for the family of 26 individuals for which the City Council adopts to be in the amount of \$3,321,000 inside the 26 homes is severely damaged when individuals cannot afford to pay \$5.56 per gallon of heating fuel or \$278.00 a drum the individual usually reverts to wood stove heating.

When subzero temperatures the water in homes freeze including the water line and other times cracks main toilet system, the City of Emmonak do not repair these damages because they are individual responsibility. The cost of frozen Water & Sewage pipes is very expensive for the individuals, they are mostly jobless or they did not earn enough during commercial fishing.

Without potable Water & Sewer System at home is not healthy.

**LOCATED WITHIN CURRENT MAIN CITY WATER/SEWER INFURSTRUCTURE**

**NEED COMPLETE WATER/SEWER HOOK UP AND PLUMBING**

EVAN AKETACHUNAK – BUCKET  
NORMA EDWARDS – BUCKET  
REBECCA EDWARDS – BUCKET  
THEODORE HAMILTON – BUCKET  
DARREN HOOTCH – BUCKET  
DOUGLAS HOOTCH – BUCKET  
HERMAN IMMAMAK – BUCKET  
JOSEPH KAMEROFF – BUCKET  
PIUS KASSOCK – BUCKET  
PAUL KELLY  
TASHA MOORE  
KAREN PETERS  
SACREDHEART CATHOLIC CHURCH  
RUTH SMITH – BUCKET  
PATRICK WASKEY – BUCKET  
JACK YUPANIK – BUCKET  
CHARLIE HOOTCH – BUCKET  
PAUL JOHN KAMEROFF – BUCKET  
DARREN JENNINGS – BUCKET  
TREVOR REDFOX

**PIPES THAT NEED MAJOR CHANGING – W/S LINE HARDEN RESIDUE PLUG LINES**

AMBROSE SHORTY  
GORDON WESTLOCK, SR.  
MOSES HARPAK

**26 HOMES @ 123.000 X = \$3,321.000**



THE STATE  
of ALASKA

GOVERNOR MICHAEL J. DUNLEAVY

Department of Environmental  
Conservation

DIVISION OF WATER  
Village Safe Water Program

P.O. Box 111800  
Juneau, AK 99801  
Main: 907-465-6594  
Fax: 907-465-5177  
www.dec.alaska.gov

October 1, 2019

Wilbur Hootch, Mayor  
PO Box 9  
Emmonak, Alaska 99581

received  
10/10/19

Dear Honorable Mayor Hootch,

The State of Alaska, Village Safe Water Program, in conjunction with the Alaska Native Tribal Health Consortium, is pleased to offer the City of Emmonak the attached Grant Agreement, 20AR92 Water and Sewer Service to One Home, in support of our cooperative efforts to develop sustainable sanitation facilities. Please review this Agreement carefully, and if satisfactory, sign the first page titled "Grant Agreement" where indicated, and return the signed original to the following address:

Village Safe Water Program  
Attn: Kris Jedlicki, Grants Administrator  
555 Cordova Street  
Anchorage, Alaska 99501

All other attachments should be retained for your records.

Nothing in this Agreement whether accepted or not accepted, may be deemed to constitute an obligation on the part of the Department until the signed Agreement has been received.

Sincerely,

A handwritten signature in blue ink, appearing to read "Amber LeBlanc".

Amber LeBlanc  
Acting Director

Enclosure: Grant Agreement

cc: Donald Olson, State Senator  
Neal Foster, State Representative  
Sean Lee, Village Safe Water Project Engineer





State of Alaska  
 Department of Environmental Conservation  
 Village Safe Water Program

**Grant Agreement**

Community Code EMK	VSW Project Number 20AR92	ANTHC Project Number AN 19-C3G	Estimate of Funds \$123,000
-----------------------	------------------------------	-----------------------------------	--------------------------------

Project Title  
Water and Sewer Service to One Home

CFDA Number 93.210	CFDA Title Tribal Self Governance Program
-----------------------	--

Grantee		Grantor	
Name City of Emmonak		Department of Environmental Conservation, Village Safe Water Program	
Street/PO Box PO Box 9		555 Cordova Street	
City/State/Zip Emmonak, AK 99581		Anchorage, AK 99501	
Contact Name & Title Wilbur Hootch, Mayor		Contact Name & Title Sean Lee, Project Engineer	
Phone (907) 949-1227		Phone (907) 269-7502	Fax (907) 269-7509

**AGREEMENT**

The Department of Environmental Conservation (hereinafter 'Department') and the City of Emmonak (hereinafter 'Grantee') agree as set forth herein.

**Section I.** Upon execution of this Agreement, and under the terms included herein, the Department shall administer funds, subject to appropriation and availability, to accomplish the scope of work described in Article A, Section 1. The estimated cost of this scope of work is identified in Article A, Section 2.

**Section II.** Performance under this Agreement begins upon signature by the Division of Water's Director and ends at Project completion.

**Section III.** This Agreement becomes null and void if not signed by the Grantee within 90 days of the Department's signature.

**Section IV.** The Agreement consists of this page and the following attachments and appendices:

**ATTACHMENTS**

- Article A: Project Outline
- Article B: General Conditions
- Article C: Construction Related Funding Conditions

**APPENDICES**

- Appendix 1: Village Safe Water Policies

Grantee	Department
Signature	Signature 
Printed Name and Title Wilbur Hootch, Mayor	Printed Name and Title Amber LeBlanc, Acting Director, Division of Water
Date	Date 10.1.19

## ARTICLE A. PROJECT OUTLINE

Subject to appropriation and availability of funds, funding will be made available under this Agreement and will be used only to pay eligible costs to perform the scope of work stated herein. The Department will serve as an agent to the Grantee during the administration of this project on behalf of Alaska Native Tribal Health Consortium (ANTHC). The Grantee will spend monies awarded under this grant only for the scope of work in this Agreement.

### Section 1. Project Scope of Work

This Agreement provides funding for water and sewer to one home in the form of a carrier pipe (utilidor) via hookup to the main.

### Section 2. Project Cost Estimate

Scope Item	Total Estimated Cost	Source of ANTHC Federal Funding
EMT Engineering, Management & Travel	\$12,300	IHS Regular Funds
I HI In-House Inspection	\$6,000	IHS Regular Funds
M-UI Utilities, Insurance, Rent	\$5,000	IHS Regular Funds
C-IU Utilidor	\$99,700	IHS Regular Funds
<b>TOTAL</b>	<b>\$ 123,000</b>	<b>IHS Regular Funds</b>

### Section 3. Changes to Project Scope

Any significant changes to the project scope of work must be approved by the Department. The scope of work for any design or construction project must remain consistent with the current Department approved Sanitation Master Plan, Comprehensive Plan, Feasibility Study, or Preliminary Engineering Report, if applicable.

**CITY OF EMMONAK  
COVID – 19  
DOCUMENT 4**

1. Lack of resources and no jobs for commercial fisherman
2. The hardship provision relates to disconnect to public services to Water/Sewer for nonpayment
3. City Council authorizes to connect all individuals to Water/Sewer service lines to that effect Water Treatment Plant City employees and accounting dept. are notified

## **HARDSHIP PROVISION 2020 COVID – 19**

Emmonak population is about 857 well-known commercial fishing industry oriented. Commercial fishing industry 2019 has been slightly under 60% what it has been for commercial fishing season 2018. Some fishermen were able to pay their bills while others did not do well.

Y1, Y2 and Y3 fishing districts have not recovered from fishing disaster when in 1999 a disaster that closed commercial harvest of chinook salmon had over 6-million-dollar value an income to 700 commercial fisherman permit holders and boat crew member helpers.

Was healthy with added income from small chum salmon commercial harvest.

Today reflection of no commercial harvest of chinook salmon still lingers on. Many sacrifices had been made about having commercial harvest for permit holders many have volunteered to retired without renewal of their permit, otherwise they knew they would in deeper debt. Many commercial fish buyers have closed their fish processing operation and or other forced to bankruptcy.

The Yukon Delta Region, however continues to keep small chum salmon commercial harvest open with the assistance of the CDQ Group. The Yukon Delta Fisheries Development Association (YDFDA). And it's subsidiary Kwikpak Fisheries keeps the hopes of fisherman alive.

Many financial sacrifices and exorbitant expenses of spending by YDFDA to find small chum salmon market in the U.S. was a heavy-duty challenge creating a new value-added market was achieved but not

good as they have hoped. Today commercial harvest of small chum salmon is half the commercial size fleet of dedicated individuals. The financial hardship prevails with unpaid balance of \$13,549.00 to their Water and Sewer bill.

With that information we know the individual fisherman having hard time paying all expenses for stove oil, electricity, water & sewer bills, clothing and groceries. With 2020 escalating costs for everything it is difficult for many village individuals to meet all demanding costs.

The Council has volunteered to help elderly and the disabled with water & sewer service where hardship prevails and the City will provide potable water to prevent COVID – 19 Virus.

**2020 POTABLE WATER COVID – 19 HARDSHIP PROVISION**

**OUTSTANDING BILLS – FOLSK LISTED BELOW ARE NOT ABLE TO PAY  
WATER/SEWER BILLS, THEREFORE DISCONNECTED**

MELVIN AGWIAK  
PAUL ANDREWS  
LEONARD AUGUSTINE, JR.  
JOHN S. BIRD  
JONATHAN BORKOWSKI  
ALOYSIUS CRANE, J.R  
LENORA HOOTCH  
PIUS KASSOCK  
CHARLIE REDFOX, JR.  
LOARRAINE REDFOX  
VITUS REDFOX  
MAXINE SAN  
THERES UISOK  
IDA AGATHLUK  
EVAN AKETACHUNAK  
THEODORE HAMILTON  
DARREN HOOTCH  
HERMAN IMMAMAK  
JOSEPH KAMEROFF  
PIUS KASSOCK  
TASHA MOORE  
KAREN PETERS  
JACK YUPANIK

**TOTAL UNPAID BALANCE \$13,549.00**